



Quality Built,
High Performance,
Maximum Dependability....

Bag Making Machinery

CONVERTING EQUIPMENT FOR FLEXIBLE MATERIALS
A commitment to meet your bag production needs.



PRO DOING INDUSTRIAL CO. LTD.
葆俊企業股份有限公司



Quality Built,
 High Performance,
 Maximum Dependability....



Profile

CHALLENGE FOR THE 21ST CENTURY

Since its establishment in 1991, PRO DOING INDUSTRIAL CO., LTD. has concentrated our efforts towards the design and manufacture of converting equipment for flexible packing materials. Our product range includes slitting, lamination and pouch making machines.

The effects of technological innovation these days are astonishing in all fields, and the demands of customers are becoming more numerous and complex.

In dealing with conditions such as these, we offer the best possible service to meet our customers' needs. We are also breaking with the convention of acting as a simple manufacturer, and aiming to become a multi-faceted corporation with the capacity for industrial rationalization. For that purpose, we are utilizing all our efforts to realize professional training of employees and expansion of management constitution.

Please know that doing business with you brings us great pride and satisfaction. We always appreciate any ideas that you can offer that would be helpful toward providing you with the best service.

SGS Taiwan Ltd.
 MD Services
 134, Wu Kong Road,
 Kung San, Taichung, Taiwan, R.O.C.
 Tel: +886-4-2359-1279
 Fax: +886-4-2359-1858

Certificate No: E2200830303

VERIFICATION OF MD COMPLIANCE

SGS-TW Reference No.	EZ200830303
Model No.	BJ-H-TN600
Product Name	Three side seal bag making machine with stand-up pouch & zipper forming
Applicant	Pro Doing Industrial Co., Ltd
Address of Applicant	#F No 47, Industrial Park 22th Road, Nan-Tun Dist, Taichung City, Taiwan.
SGS approved laboratory	SGS Taiwan
Date of Issue	March 7, 2006
Applicable Standards	EN ISO 12100-1:2003, EN ISO 12100-2:2005, EN294:1992, EN 349:1993, EN1050:1996, EN254-1:1995, EN 983:1997, EN 60204-1:1997

Conclusion
 Based upon a review of the worksheets and the Technical Construction File, the apparatus is deemed to meet the requirements of the above standards and hence fulfils the requirements of:

Machinery Directive 89/392/EEC
 Low Voltage Directive 73/23/EEC as amended by 93/68/EEC

Note: This certificate is only valid for the equipment and configuration described, and in conjunction with the test data detailed above.

Authorized Signatory:

 JASON LIN
 SGS TAIWAN LTD.

Copyright of this certificate is owned by SGS Taiwan MD Services and may not be reproduced other than in full and with the prior approval of the Manager of SGS Taiwan D Services.

SGSPAPER 04254162



Quality Built,
High Performance,
Maximum Dependability....



i Contents

BAG MAKING PROCESS	1			
PVC SHRINKABLE LABEL MAKING PROCESS	2			
DRY LAMINATING MACHINE乾式貼合機BJDL-800	3			
DRY LAMINATING MACHINE乾式貼合機BJDL-D1000	4			
WET LAMINATING MACHINE濕式貼合機BJWL-1000/1300	5			
SLITTING MACHINE-H型S分條機BJL-H1000S(representative)	6			
SLITTING MACHINE-H型分條機BJL-H1000(With unloading device)	7			
SLITTING MACHINE-H型分條機BJL-H1000(representative)	8			
SLITTING MACHINE-K型分條機BJL-K1000/1300/1600(representative)	9			
SLITTER MACHINE-BK型分條機BJL-BK1300(representative)	10			
INSPECTION & REWINDER正逆轉檢品複捲機BJRV-1300(representative)	11			
INSPECTION & REWINDER檢品複捲機BJRV-600(representative)	12			
THREE SIDE SEALING BAG MAKING MACHINE				
WITH STAND-UP POUCH & ZIPPER BAG FORMING DEVICE				
三封機+站立袋+拉鍊袋機BJ-H-TN600(representative)	13	14		
THREE-SIDE-SEALING AUTOMATIC BAG MAKING MACHINE				
三封機BJTC-500NV/600NV(representative)	15			
CENTER SEALING & GUSSET BAG MAKING MACHINE WITH SERVO MOTOR				
伺服控制自動合掌製袋機BJKC-600NV/500NV(representative)	16			
AUTO SERVO CONTROL FIVE-SIDE SEALING BAG MAKING MACHINE				
全自動伺服控制五面封製袋機BJKC-600FV	17	18		
PRESSING TYPE CENTER-SEALING & GUSSET BAG MAKING MACHINE				
壓式合掌機BJKA-350(representative)	19			
FIVE-STEPS SEAL CUTTER五段式封切機BJC-355V(representative)	20			
CENTER-SEALING & GUSSET MACHINE合掌機BJK-300(representative)	21			
SEAL CUTTER MACHINE封剪機BJC-354V(representative)	22			
MEDICAL BAG MAKING MACHINE醫療專用製袋機BJCD-700V(representative)	23			
SIDE SEAL & REWINDER(MULTI-LINE) 管袋機BJTA-700(representative)	24			
CENTER GLUING MACHINE(MODELESS TYPE) PVC/PET無模板黏合機BJKS-300-P(representative) ..	25			
CENTER GLUING MACHINE(MODELESS TYPE) PVC/PET無模板黏合機BJKN-300-P(representative) ..	26			
CUTTING MACHINE WITH SERVO MOTOR切片機BJC-300-PS(representative)	27			
INSPECTION & REWINDER複捲機BJRV-300(representative)	28			
SHRINKABLE LABEL MAKING PROCESS收縮標籤製造機 (標準型)	29	30	31	32
SHRINKABLE LABEL MAKING PROCESS CE收縮標籤製造機 (CE型)	33	34	35	36
SLITTING MACHINE分條機	37	38	39	40

Quality Built,
High Performance,
Maximum Dependability....



PRO DOING INDUSTRIAL CO., LTD.
BAG MAKING MACHINERY

● Bag Making Process

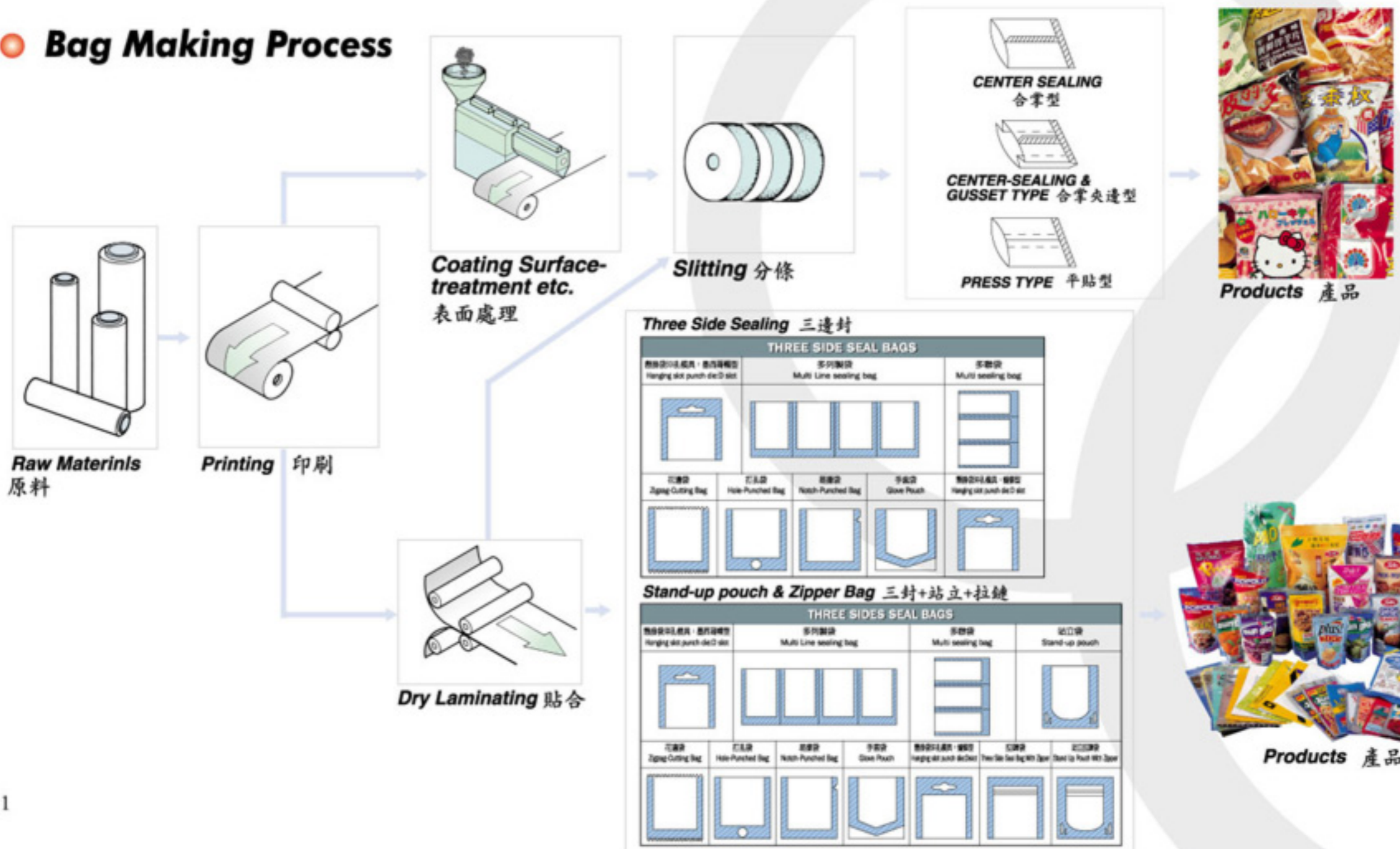

● **PVC Shrinkable Label Making Process**

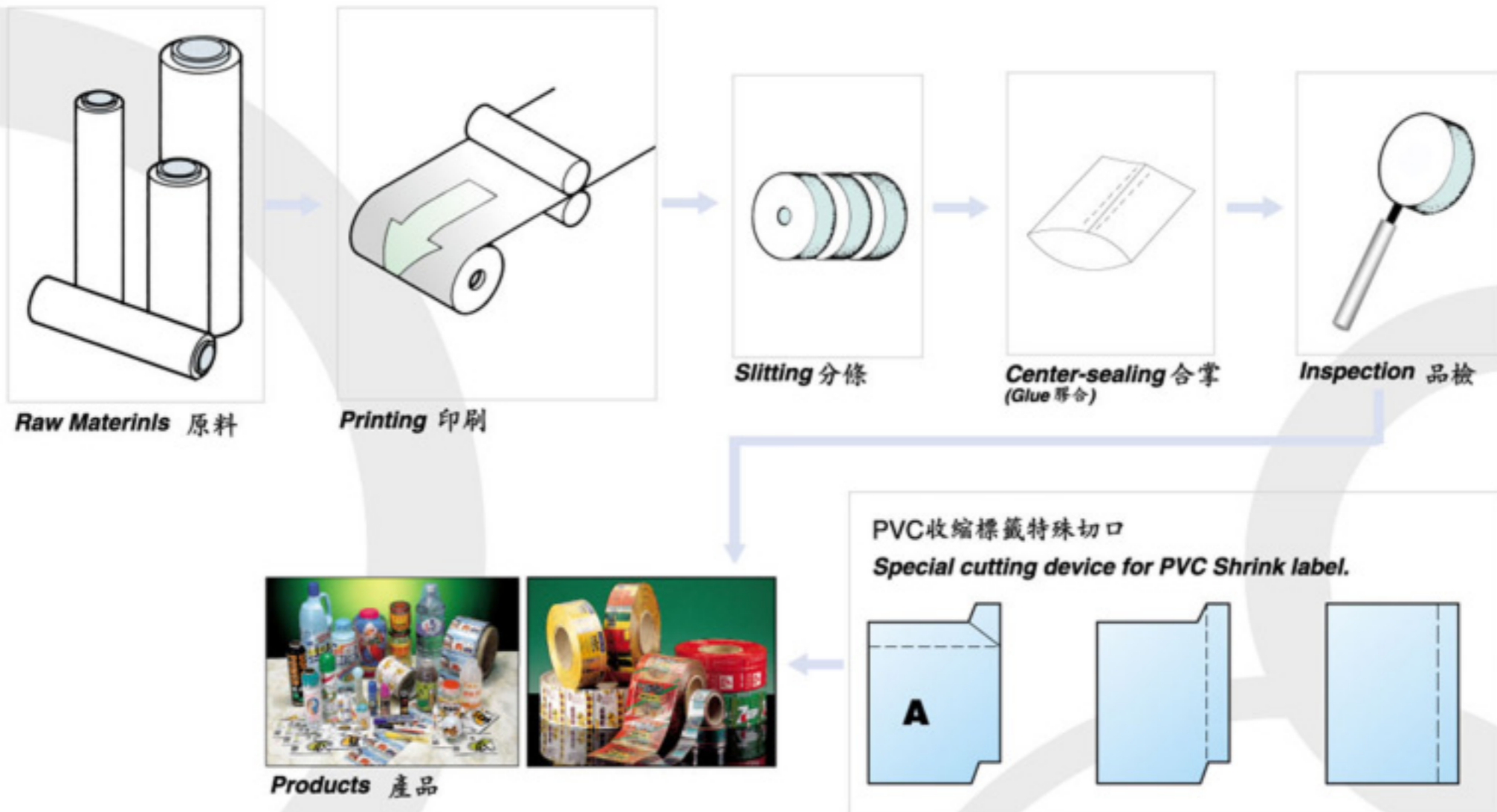

Quality Built,
High Performance,
Maximum Dependability....

乾式貼合機

(Gravure Mesh Rotary Type)

DRY LAMINATING MACHINE

BJDL-800 (representative)



3

Pro Doing machine

PRO DOING INDUSTRIAL CO. LTD.

No. 47, 22nd. Road, Taichung Industrial Park, Taichung City, Taiwan.

TEL: 886-4-2359-7712 FAX: 886-4-2359-7269

Email: prodoing@ms36.hinet.net <http://www.prodoing.com>

乾式貼合機

(Deluxe Type)

DRY LAMINATING MACHINE

BJDL-D1000 (representative)



適用材質：

各種軟性包裝材料如BOPP, CPP, PET, PE, NYLON, 電鍍鋁膜及各種多層膠膜之貼合及表面處理作業之材料。

SUITABLE MATERIAL:

A VARIETY OF FLEXIBLE PACKAGING MATERIALS, EX: BOPP, CPP, PET, PE, NYLON, ELECTROPLATING ALUMINUM FOIL...ETC.

SPECIFICATIONS 規格

型式	MODEL	BJDL-800	BJDL-D1000
原料寬度	Unwind Width	400 ~ 800 mm	400 ~ 1000 mm
原料直徑	Unwind Diameter	800 mm	800 mm (max)
塗佈方式	Coating Method	Gravure Mesh Rotary Type	Gravure Mesh Rotary Type
成品直徑	Rewind Diameter	800 mm	800 mm
機械速度	Machine Speed	220 m/min	0 ~ 180 m/min
電 壓	Power	220V / 380V / 440V, 3-PHASE, 50/60 HZ	220V / 380V / 440V, 3-PHASE, 50/60 HZ

由於本公司不斷的研究改進，本型號所示機械規格特性本公司有變更之權利，恕不另行通知。
All specifications, designs and characteristics shown on this catalogue are subject to change without prior notice.

Quality Built,
High Performance,
Maximum Dependability....



溼式貼合機

WET LAMINATING MACHINE

BJWL-1000/1300 (representative)



適用材質：

各種軟性包裝材料如BOPP, CPP, PET, PE, NYLON, 電鍍鋁膜及各種多層膠膜之貼合及表面處理作業之材料。

SUITABLE MATERIAL:

A VARIETY OF FLEXIBLE PACKAGING MATERIALS, EX: BOPP, CPP, PET, PE, NYLON, ELECTROPLATING ALUMINUM FOIL...ETC.

SPECIFICATIONS 規格

型式	MODEL	BJWL-1000	BJWL-1300
原料寬度	Unwind Width	400 ~ 1000 mm	400 ~ 1300 mm
原料直徑	Unwind Diameter	500 mm (AL-FOIL) ~ Ø1000 mm (PAPER)	500 mm (AL-FOIL) ~ Ø1000 mm (PAPER)
塗佈方式	Coating Method	Closing Chamber Type	Closing Chamber Type
成品直徑	Rewind Diameter	1000 mm (max.)	1000 mm (max.)
機械速度	Machine Speed	150 m/min	150 m/min
電 壓	Power	220V, 380V, 440V, 3-PHASE, 50/60 HZ	220V, 380V, 440V, 3-PHASE, 50/60 HZ

由於本公司不斷的研究改進，本型號所示機械規格特性本公司有變更之權利，恕不另行通知。
All specifications, designs and characteristics shown on this catalogue are subject to change without prior notice.

H型S分條機

SLITTING MACHINE

BJL-H1000S (representative)



Pro Doing machine

6

PRO DOING INDUSTRIAL CO. LTD.

No. 47, 22nd. Road, Taichung Industrial Park, Taichung City, Taiwan.

TEL: 886-4-2359-7712 FAX: 886-4-2359-7269

Email: prodoing@ms36.hinet.net <http://www.prodoing.com>

Quality Built,
High Performance,
Maximum Dependability....



H 型分條機

SLITTING MACHINE

BJL-H1000 (With unloading device)



7

Pro Doing machine

PRO DOING INDUSTRIAL CO. LTD.

No. 47, 22nd. Road, Taichung Industrial Park, Taichung City, Taiwan.

TEL: 886-4-2359-7712 FAX: 886-4-2359-7269

Email: prodoing@ms36.hinet.net <http://www.prodoing.com>

H 型分條機

SLITTING MACHINE

BJL-H1000 (representative)



適用材質：

OPP, PET, CPP, PVC(軟質), PVC 收縮膜, PP 收縮膜, PE,不織布...等塑膠膜類。

SUITABLE MATERIAL:

OPP, PET, CPP, PVC (Soft type), PE, SHRINK FILM, PP SHRINK FILM, NON-WOVEN FABRICS...ETC.

SPECIFICATIONS 規格

型式	MODEL	BJL-H1000S	BJL-H1000
原料寬度	Unwind Width	200 ~ 1000 mm	300 ~ 1000 mm
原料直徑	Unwind Diameter	800 ~ 1300 mm	700 mm (max)
成品寬度	Rewind Width	50 ~ 1000 mm	50 ~ 1000 mm
成品直徑	Rewind Diameter	700 mm (max)	450 mm (max)
紙管內徑	Core I.D.	3"	3"
機械速度	Machine Speed	0 ~ 200 m/min	0 ~ 300 m/min
電 壓	Power	220V / 380V / 440V, 3-PHASE, 50/60 HZ	220V / 380V / 440V, 3-PHASE, 50/60 HZ

由於本公司不斷的研究改進，本型號所示機械規格特性本公司有變更之權利，恕不另行通知。
All specifications, designs and characteristics shown on this catalogue are subject to change without prior notice.

Quality Built,
High Performance,
Maximum Dependability....



K 型分條機

SLITTING MACHINE

BJL-K1000/1300/1600 (representative)



適用材質：

OPP、PET、CPP、PVC(軟質)、收縮膜等
塑膠膜類。

SUITABLE MATERIAL:

OPP, PET, CPP, PVC (Soft type), SHRINK FILM...
ETC.

SPECIFICATIONS 規格

型式	MODEL	BJL-K1000	BJL-K1300
原料寬度	Unwind Width	300 ~ 1000 mm	400 ~ 1300 mm
原料直徑	Unwind Diameter	700 mm	700 mm
成品寬度	Rewind Width	50 ~ 1000 mm	50 ~ 1300 mm
成品直徑	Rewind Diameter	450 mm	450 mm
紙管內徑	Core I.D.	3"	3"
機械速度	Machine Speed	0 ~ 250 m/min	0 ~ 250 m/min
電 壓	Power	220V / 380V / 440V, 3-PHASE, 50/60 HZ	

由於本公司不斷的研究改進，本型號所示機械規格特性本公司有變更之權利，恕不另行通知。
All specifications, designs and characteristics shown on this catalogue are subject to change without prior notice.

BK型分條機

SLITTER MACHINE

BJL-BK1300 (representative)



適用材質：

OPP, PET, CPP, PVC(硬質), 紙, 離型紙, 電鍍紙, 鋁箔紙, 玻璃紙, 自粘商標紙, 碳帶, 緞帶。

SUITABLE MATERIAL:

OPP, PET, CPP, PVC(HARD TYPE), PAPER, RELEASE PAPER, ALUMINUM FOIL, CELLOPHANE, LABEL PATER, RIBBON.

SPECIFICATIONS 規格

型式	MODEL	BJL-BK1300	BJL-BK1600
原料寬度	Unwind Width	300 ~ 1300 mm	300 ~ 1600 mm
原料直徑	Unwind Diameter	700 mm (max)	800 mm
成品寬度	Rewind Width	50 ~ 1000 mm	40 ~ 1000 mm
成品直徑	Rewind Diameter	600 mm (max)	600 mm
紙管內徑	Core I.D.	3"	3"
機械速度	Machine Speed	0 ~ 200 m/min	0 ~ 200 m/min
電 壓	Power	220V / 380V / 440V, 3-PHASE, 50/60 HZ	220V / 380V / 440V, 3-PHASE, 50/60 HZ

由於本公司不斷的研究改進，本型號所示機械規格特性本公司有變更之權利，恕不另行通知。
All specifications, designs and characteristics shown on this catalogue are subject to change without prior notice.

machine

Quality Built,
High Performance,
Maximum Dependability....



正逆轉檢品複捲機

INSPECTION & REWINDER

BJRV-1300 (representative)



11

SPECIFICATIONS 規格

型式	MODEL	BJRV-1300
原料寬度	Unwind Width	300 ~ 1300 mm
原料直徑	Unwind Diameter	800 mm (max)
成品寬度	Rewind Width	1300 mm
成品直徑	Rewind Diameter	800 mm (max)
紙管內徑	Core I.D.	3" Paper core
機械速度	Machine Speed	0 ~ 250 m/min
電 壓	Power	220V / 380V / 440V, 3-PHASE, 50/60 HZ

由於本公司不斷的研究改進，本型號所示機械規格特性本公司有變更之權利，恕不另行通知。
All specifications, designs and characteristics shown on this catalogue are subject to change without prior notice.

Pro Doing

檢品複捲機

INSPECTION & REWINDER

BJRV-600 (representative)



SPECIFICATIONS 規格

型式	MODEL	BJRV-600
原料寬度	Unwind Width	20 ~ 600 mm
原料直徑	Unwind Diameter	400 mm (max)
成品寬度	Rewind Width	20 ~ 600 mm
成品直徑	Rewind Diameter	400 mm (max)
紙管內徑	Core I.D.	Unwind 3"+6" ,Rewind 3"+6"
機械速度	Machine Speed	0 ~ 300 m/min
電 壓	Power	220V / 380V / 440V, 3-PHASE, 50/60 HZ

由於本公司不斷的研究改進，本型錄所示機械規格特性本公司有變更之權利，恕不另行通知。
All specifications, designs and characteristics shown on this catalogue are subject to change without prior notice.

machine



Quality Built,
High Performance,
Maximum Dependability....

三封機 + 站立袋 + 拉鍊袋機

THREE SIDE SEALING BAG MAK

BJ-H-TN600 (representative)

FEATURES:

The pouch making machine from Pro Doing is the result of recent exhaustive R&D.

The challenges overcome, promise a much more competitive product. The exclusive 'pulsating condenser mould plate' is used in the zipper sealing unit to give a beautiful finished product to the pouches. The 'stand-up unwind pushing type' ensures a precise moving length of materials. When the machine is stopped, the heating mould plates cool down automatically.

Side sealing is positioned by the specially-equipped photo cell.

Automatic unwind ensures optimum working performance.

Additionally, this machine is designed with a full servo drive system.

Seven sets of servo sectional control drives are standard equipment that allow for high-speed pouch making.

特性：

本製袋機是傑俊公司近年來精心研發的成果。過程中，我們克服了種種的困難與挑戰，就是要確保並展現一部真正具有市場競爭力的優良製袋機器。運用獨特的「跳動式散熱模」，並將其連結使用在拉鍊帶子的封合製程中，使得成品袋上拉鍊的封合更加的完美無瑕。另外，「推式站立袋原料座」使出料準確，絕不會造成原料的拉伸或打滑。停車時，花模會自動下降分離原料，避免原料繼續受熱而變形。邊封追蹤電眼裝置，使封口準確絕不移位。原料自動上料裝置，更加省時省力，並提升作業效率。且本機器具備完整的伺服驅動系統，七組伺服馬達控制系統已為本機器的標準配備，讓製袋速度更加的精準與快速。



ING MACHINE WITH STAND-UP POUCH & ZIPPER BAG FORMING DEVICE

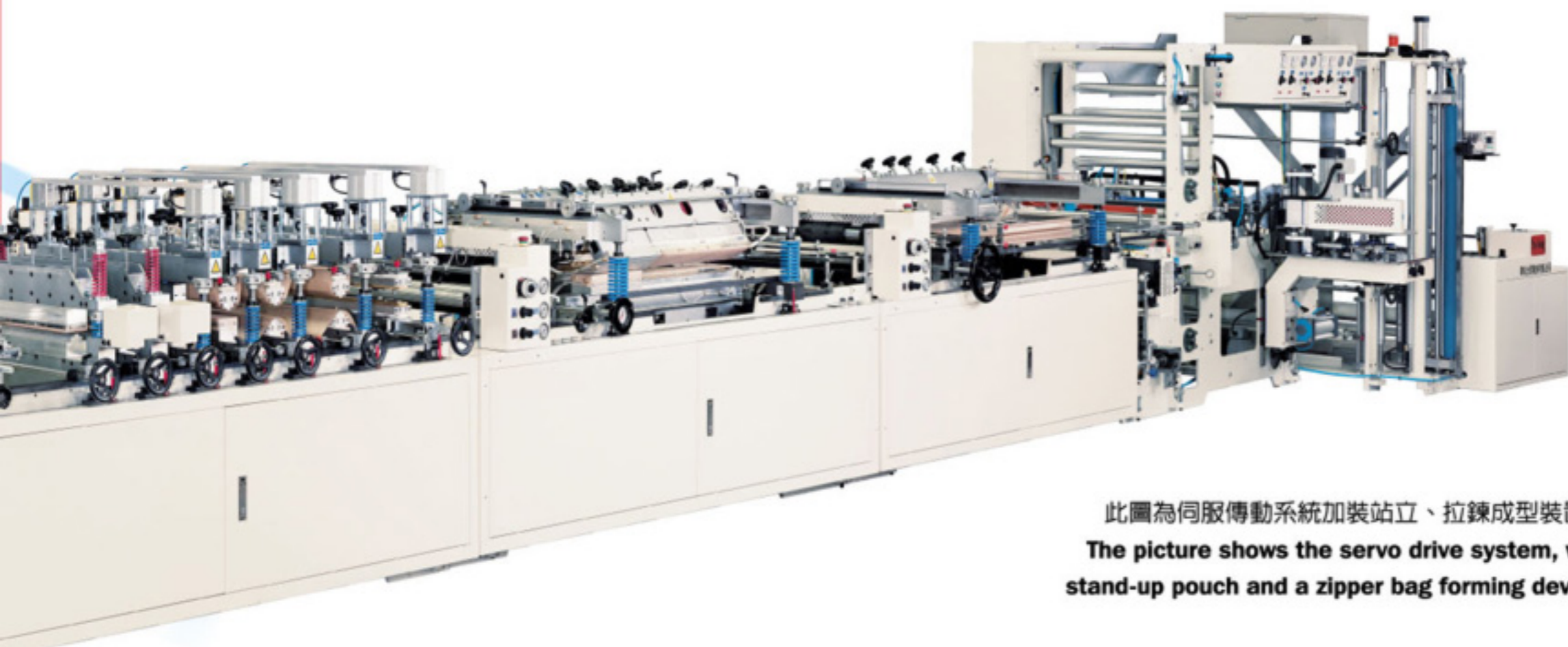

此圖為伺服傳動系統加裝站立、拉鍊成型裝置。
The picture shows the servo drive system, with stand-up pouch and a zipper bag forming device.



SPECIFICATIONS 規格

型式	MODEL	BJ-H-TN600
原料寬度	Unwind Width	500 ~ 1200 mm
原料直徑	Unwind Diameter	600 mm (max.)
製袋長度	Bag Making Length	30 ~ 300 mm
製袋寬度	Bag Making Width	80 ~ 600 mm
製袋列數	Production Lines	For three side sealing: 1 ~ 2 Lines
製袋速度	Production Speed	For three side sealing: 35 m/min, For three side sealing with Stand-up pouch & Zipper: 25 m/min
電壓	Power	220V / 380V / 440V, 3-PHASE, 50/60 HZ

由於本公司不斷的研究改進，本型號所示機械規格特性本公司有變更之權利，恕不另行通知。
All specifications, designs and characteristics shown on this catalogue are subject to change without prior notice.

machine

Quality Built,
High Performance,
Maximum Dependability....



三封機

THREE-SIDE-SEAL AUTOMATIC BAG MAKING MACHINE

BJTC- 500NV/600NV (representative)



15

SPECIFICATIONS 規格

型式	MODEL	BJTC-600NV	BJTC-500NV
原料寬度	Unwind Width	300 ~ 1200 mm	300 ~ 1000 mm
原料直徑	Unwind Diameter	700 mm (max)	700 mm (max)
製袋長度	Bag Making Length	30 ~ 400 mm	30 ~ 400 mm
製袋寬度	Bag Making Width	80 ~ 600 mm	50 ~ 500 mm
製袋列數	Production Lines	1 ~ 4 Lines	1 ~ 4 Lines
機械速度	Machine Speed	36 m/min (max)	36 m/min (max)
電 壓	Power	220V / 380V / 440V, 3-PHASE, 50/60 HZ	220V / 380V / 440V, 3-PHASE, 50/60 HZ

由於本公司不斷的研究改進，本型號所示機械規格特性本公司有變更之權利，恕不另行通知。
All specifications, designs and characteristics shown on this catalogue are subject to change without prior notice.

Pro Doing

伺服控制自動合掌製袋機

CENTER SEALING & GUSSET BAG MAKING MACHINE WITH SERVO MOTOR

BJKC-600NV / 500NV (representative)

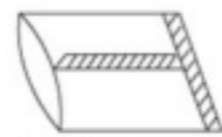

CENTER SEALING
合掌型

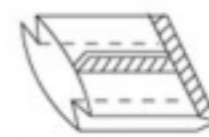

CENTER-SEALING & GUSSET TYPE
合掌夾邊型

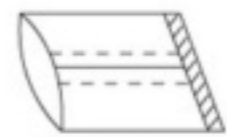

PRESS TYPE
平貼型

SUITABLE FOR

適用範圍：

Poly Bags, Vacuum Packaging

Bags, Boil Resistant Bags.

保麗袋、積層袋及耐蒸煮袋。

SPECIFICATIONS 規格

型式	MODEL	BJKC-600NV	BJKC-500NV
原料寬度	Unwind Width	120 ~ 1220 mm	120 ~ 1020 mm
原料直徑	Unwind Diameter	600 mm (max)	600 mm (max)
成品寬度	Product Width	50 ~ 600 mm	50 ~ 500 mm
成品長度	Product Length	50 ~ 400 mm	50 ~ 400 mm
機械速度	Machine Speed	0 ~ 35 m/min	0 ~ 35 m/min
電 壓	Power	220V / 380V / 440V, 3-PHASE, 50/60 HZ	

由於本公司不斷的研究改進，本型錄所示機械規格特性本公司有變更之權利，恕不另行通知。
All specifications, designs and characteristics shown on this catalogue are subject to change without prior notice.

machine

Quality Built,
High Performance,
Maximum Dependability....

全自動伺服控制五面封製袋機

AUTO SERVO CONTROL

BJKC-600FV

FEATURES:

This center sealing & gusset bag making machine with servo motor is a versatile and highly efficient unit. It combines center sealing, gusset, bottom sealing & cutting functions in one unit providing high production performance. Both utilizing locations of the gusset and unwind & middle seat makes large small bag production more flexible and smooth. The excellent design of the middle side-strip equipment assures the secure and smooth sealing of the bags. A special five side sealing function makes the finished bags more outstanding and valuable. The Human Machine Interface (HMI) and Servomotor Control Systems are standard and the resulting superior quality is praised by manufacturers.

特性：

本伺服控制自動合掌製袋機為多功能高效率機種，它集合掌，夾邊，封口切斷之功能，展現高產能特性。夾邊設備裝置於前端之原料座及中座兩處，使得大&小夾邊袋子製作深具彈性及夾邊操作更加靈活。中座邊條裝置的設計更使袋子的封口強度更強且形狀平整美觀。本機具有五面封之特殊袋型封口功能，使產出的袋子更加堅挺與超高價值感，人機操控及伺服之使用，亦為本機的基本配備，讓本機的製袋品質與價值發揮到極限。



華成企業股份有限公司
PRO DOING INDUSTRIAL CO., LTD.

OL FIVE-SIDE SEALING BAG MAKING MACHINE

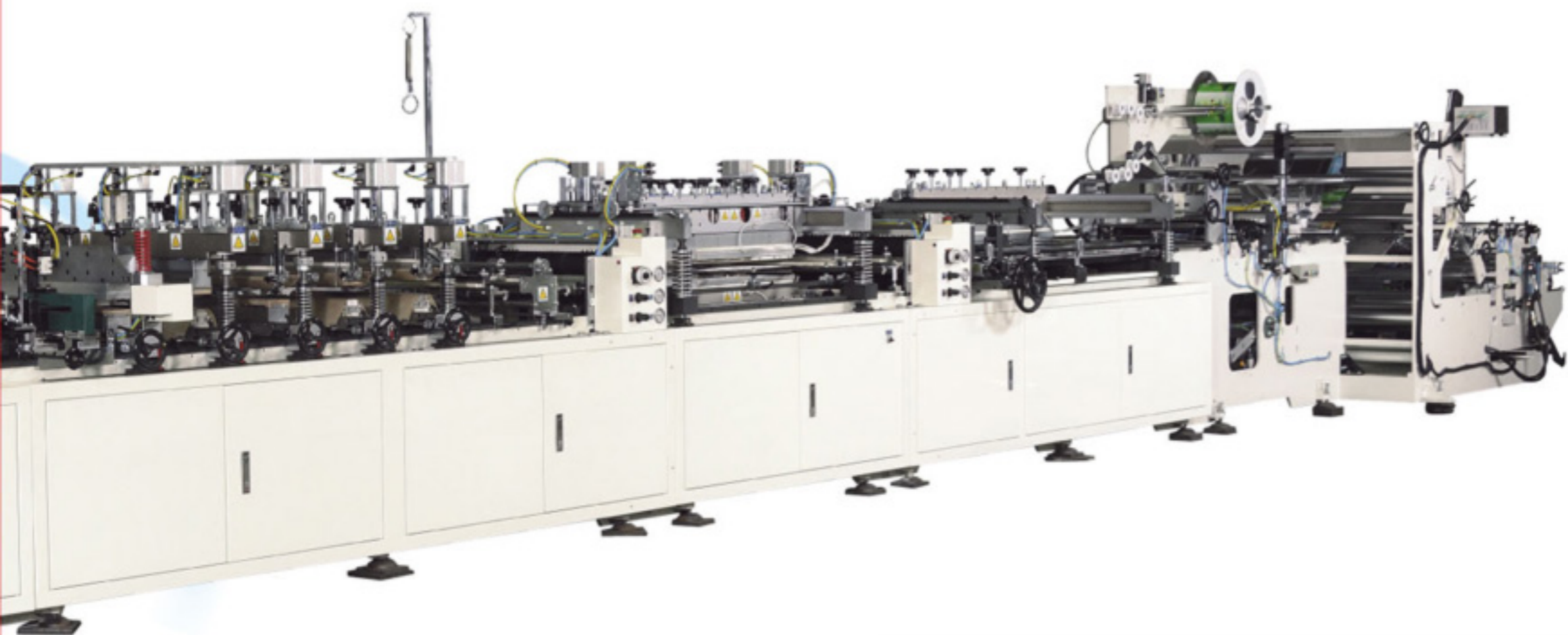

SUITABLE FOR 適用範圍：

Poly Bags, Vacuum Packaging Bags, Boil Resistant Bags.
保麗袋、積層袋及耐蒸煮袋。

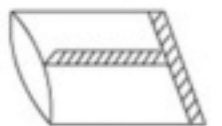

CENTER SEALING
合掌型

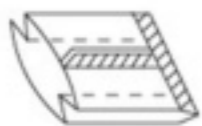

CENTER-SEALING &
GUSSET TYPE
合掌夾邊型

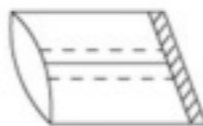

PRESS TYPE
平貼型



CENTER & SIDE SEAL
WITH GUSSET
合掌夾邊側封型

SPECIFICATIONS 規格

型式	MODEL	BJKC-600FV
原料寬度	Unwind Width	120 ~ 1220 mm
原料直徑	Unwind Diameter	600 mm (max.)
成品長度	Product Length	50 ~ 400 mm
成品寬度	Product Width	50 ~ 600 mm
機械速度	Machine Speed	0 ~ 35 m/min (依材質, 厚薄, 袋長而不同) (Depends on Material and Length.)
電 壓	Power	220V / 380V / 440V, 3-PHASE, 50/60HZ

由於本公司不斷的研究改進，本目錄所示機械規格特性本公司有變更之權利，恕不另行通知。
All specifications, designs and characteristics shown on this catalogue are subject to change without prior notice.

Quality Built,
High Performance,
Maximum Dependability....

壓式合掌機

PRESSING TYPE CENTER-SEALING & GUSSET BAG MAKING MACHINE

BJKA-350 (representative)

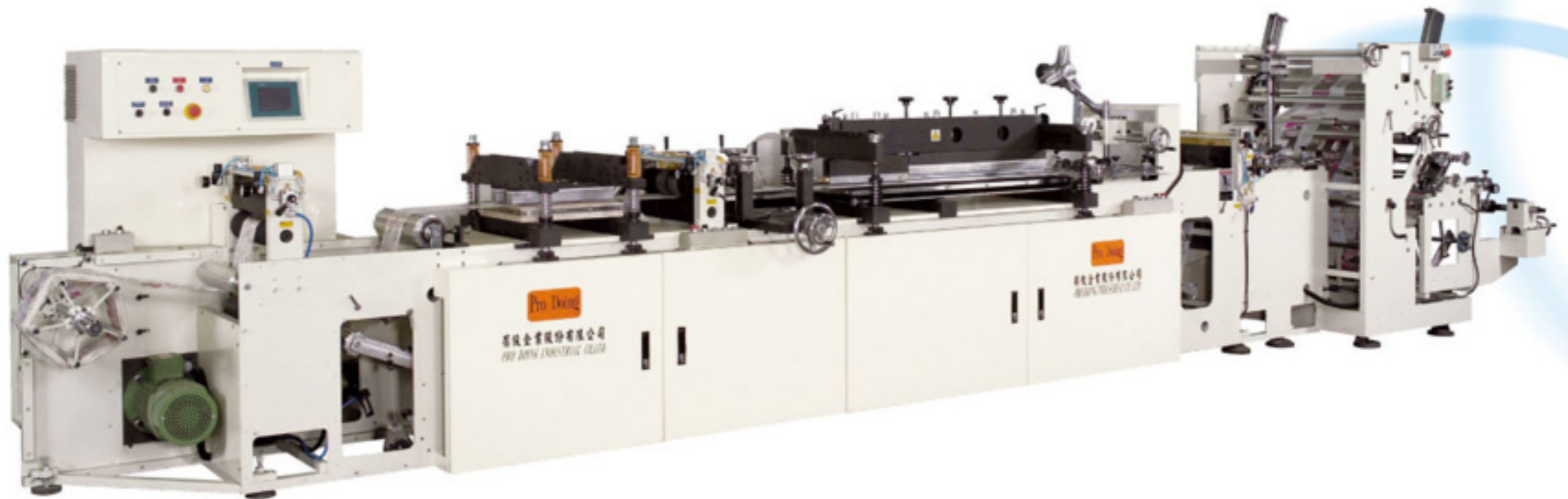

CENTER SEALING
合掌型



CENTER-SEALING &
GUSSET TYPE
合掌夾邊型

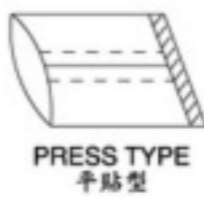

PRESS TYPE
平貼型

19

SPECIFICATIONS 規格

型式	MODEL	BJKA-350
原料寬度	Unwind Width	120 ~ 720 mm
原料直徑	Unwind Diameter	450 mm (max)
製袋長度	Bag Making Length	700 mm (max)
製袋寬度	Bag Making Width	50 ~ 350 mm
製袋列數	Production Lines	300 mm (five-claw coreless rewinder)
製袋速度	Production Speed	0 ~ 30 m/min
電 壓	Power	220V / 380V / 440V, 3-PHASE, 50/60 HZ

由於本公司不斷的研究改進，本型錄所示機械規格特性本公司有變更之權利，恕不另行通知。
All specifications, designs and characteristics shown on this catalogue are subject to change without prior notice.

Pro Doing

五段式封切機

FIVE-STEPS SEAL CUTTER

BJC-355V (representative)



SPECIFICATIONS 規格

型式	MODEL	BJC-355V
原料直徑	Unwind Diameter	700 mm (Five claw coreless for I.D.)
製袋長度	Bag Making Length	50 ~ 400 mm
製袋寬度	Bag Making Width	30 ~ 350 mm
機械速度	Machine Speed	30 ~ 180 Bags per m/min
電 壓	Power	220V / 380V / 440V, 3-PHASE, 50/60 HZ

由於本公司不斷的研究改進，本型錄所示機械規格特性本公司有變更之權利，恕不另行通知。
All specifications, designs and characteristics shown on this catalogue are subject to change without prior notice.

machine

Quality Built,
High Performance,
Maximum Dependability....

合掌機

CENTER-SEALING & GUSSET MACHINE

BJK-300 (representative)



SPECIFICATIONS 規格

型式	MODEL	BJK-300
原料寬度	Unwind Width	120 ~ 720 mm
原料直徑	Unwind Diameter	450 mm (max.)
成品寬度	Rewind Width	50 ~ 350 mm
成品直徑	Rewind Diameter	700 mm (max.)
成品內徑	Inside Rewind Diameter	300 mm (five-claw coreless rewinder)
機械速度	Machine Speed	0 ~ 60 m/min
電 壓	Power	220V / 380V / 440V, 3-PHASE, 50/60 HZ

由於本公司不斷的研究改進，本型號所示機械規格特性本公司有變更之權利，恕不另行通知。
All specifications, designs and characteristics shown on this catalogue are subject to change without prior notice.

封剪機

SEAL CUTTER MACHINE

BJC-354V (representative)

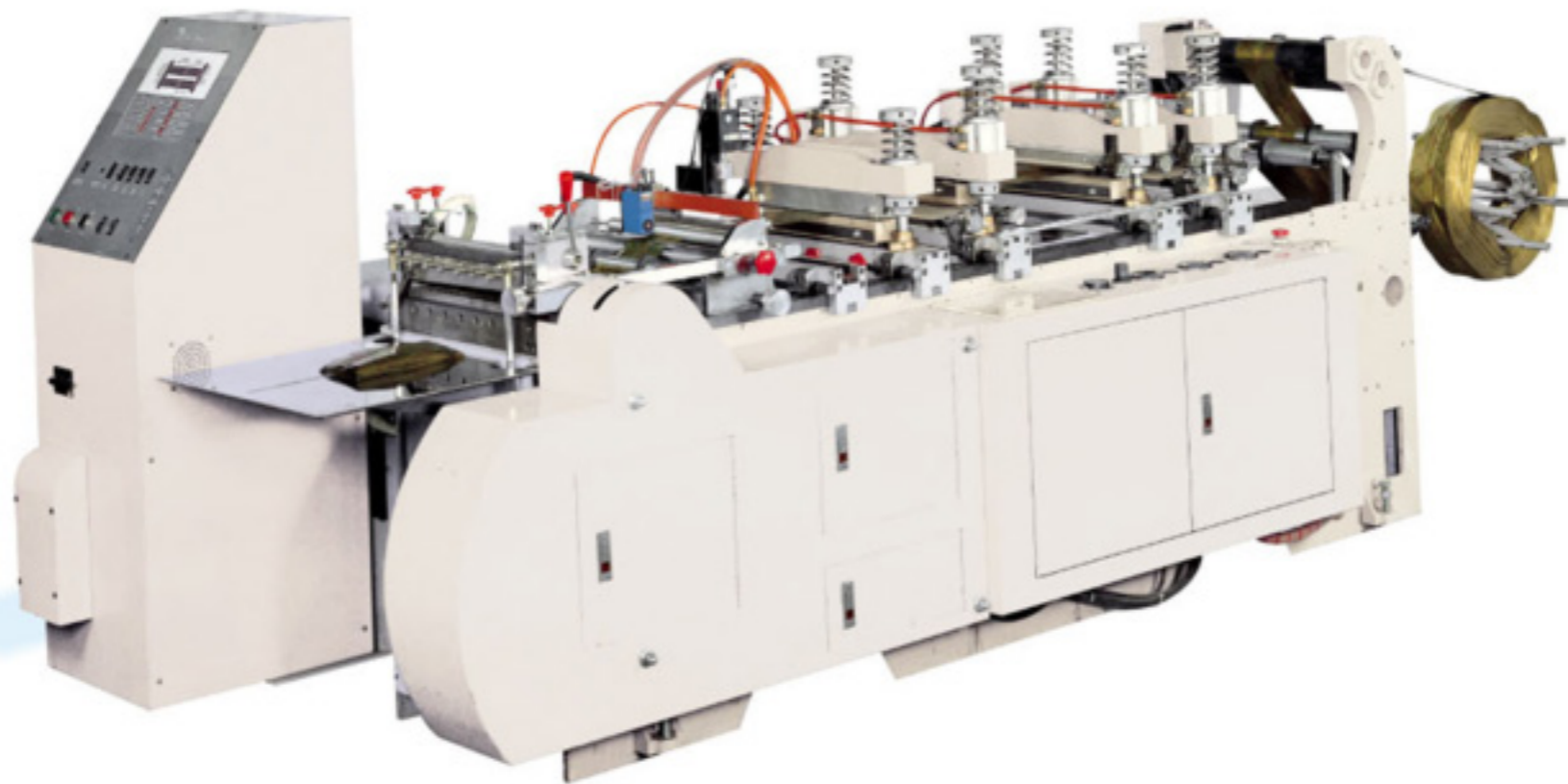

SPECIFICATIONS 規格

型式	MODEL	BJC-354V
原料直徑	Unwind Diameter	700 mm
製袋長度	Bag Making Length	50 ~ 400 mm (max)
製袋寬度	Bag Making Width	30 ~ 350 mm (max)
製袋速度	Production Speed	0 ~ 180 m/min
電 壓	Power	220V / 380V / 440V, 3-PHASE, 50/60 HZ

由於本公司不斷的研究改進，本型號所示機械規格特性本公司有變更之權利，恕不另行通知。
All specifications, designs and characteristics shown on this catalogue are subject to change without prior notice.

machine

Quality Built,
High Performance,
Maximum Dependability....



醫療專用製袋機

MEDICAL BAG MAKING MACHINE

BJCD-700V (representative)

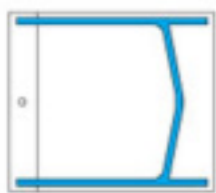

SPECIFICATIONS 規格

型式	MODEL	BJCD-700V
原料直徑	Unwind Diameter	600 mm (內徑 3" 紙管雙捲原料型) (Two Shaft With 3" Paper Core.)
製袋長度	Bag Making Length	50 ~ 620 mm (max.)
製袋寬度	Bag Making Width	30 ~ 700 mm
製袋列數	Production Lines	1 ~ 4列
機械速度	Machine Speed	0 ~ 30 m/min (100 mm 長Length).
電 壓	Power	220V / 380V / 440V, 3-PHASE, 50/60HZ

管袋機

SIDE SEAL & REWINDER (MULTI-LINE)

BJTA-700 (representative)

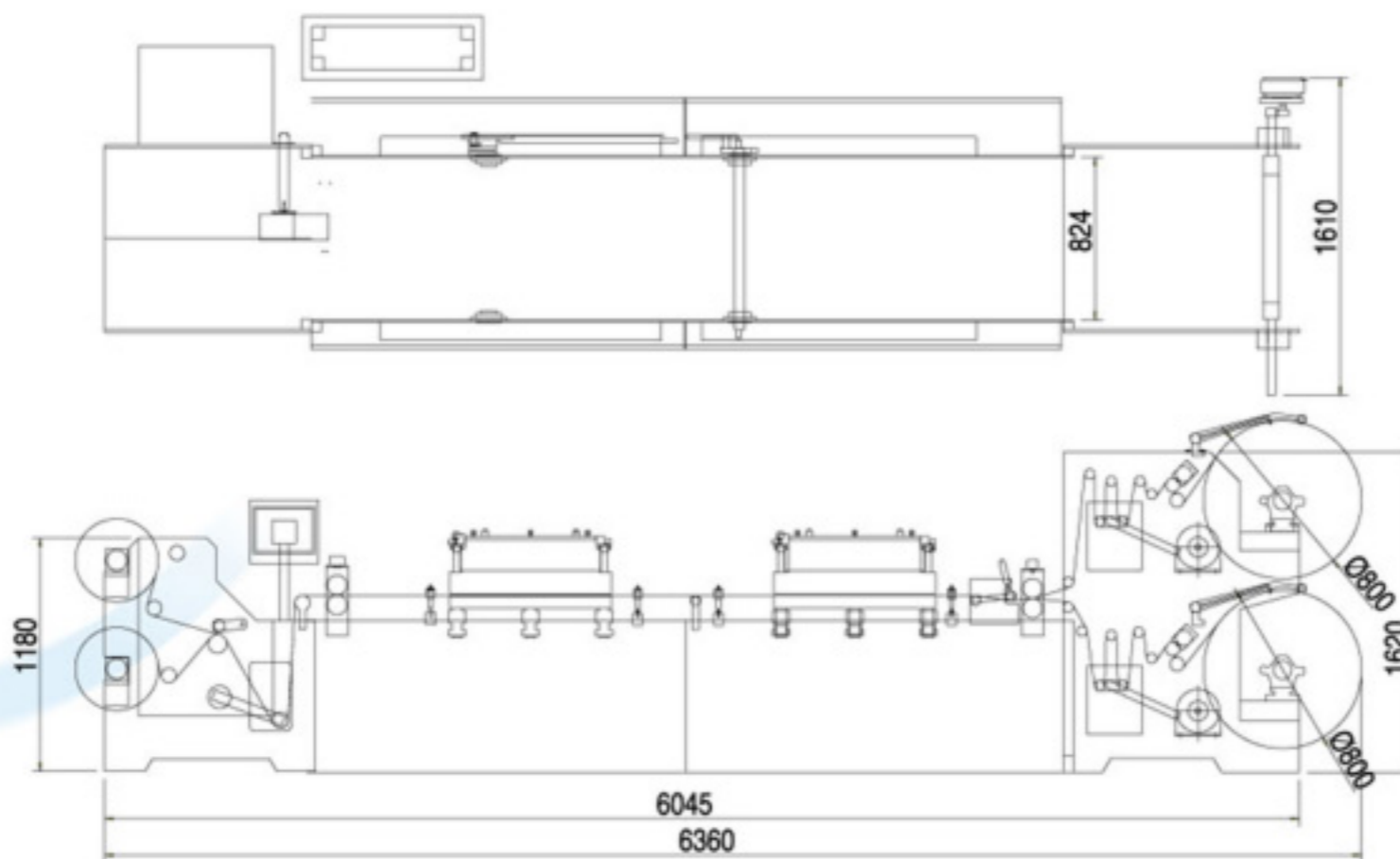

SPECIFICATIONS 規格

型式	MODEL	BJTA-700
原料寬度	Unwind Width	300 ~ 800 mm
原料直徑	Unwind Diameter	600 mm (內徑 3" 紙管雙捲原料型) (Two Shaft With 3" Paper Core.)
成品寬度	Product Width	30 ~ 700 (max)
成品長度	Product Length	50 ~ 820 mm
成品列數	Product Lines	0 ~ 12 列 LINES.
機械速度	Machine Speed	0 ~ 35 m/min
電 壓	Power	220V / 380V / 440V, 3-PHASE, 50/60HZ

由於本公司不斷的研究改進，本型號所示機械規格特性本公司有變更之權利，恕不另行通知。
All specifications, designs and characteristics shown on this catalogue are subject to change without prior notice.

Quality Built,
High Performance,
Maximum Dependability....



PVC/PET無模板黏合機 **CENTER GLUING MACHINE (MODELESS TYPE)**

BJKS-300-P (representative)



25

SPECIFICATIONS 規格

型式	MODEL	BJKS-300-P
原料寬度	Unwind Width	600 mm (max)
原料直徑	Unwind Diameter	600 mm (max)
成品寬度	Rewind Width	10 ~ 250 mm
成品直徑	Rewind Diameter	600 mm (max)
紙管內徑	Core I.D.	3"
機械速度	Machine Speed	5 ~ 300 m/min
電 壓	Power	220V / 380V / 440V, 3-PHASE, 50/60 HZ

由於本公司不斷的研究改進，本型錄所示機械規格特性本公司有變更之權利，恕不另行通知。
All specifications, designs and characteristics shown on this catalogue are subject to change without prior notice.

Pro Doing

PVC/PET無模板黏合機

CENTER GLUING MACHINE (MODELESS TYPE)

BJKN-300-P (representative)



SPECIFICATIONS 規格

型式	MODEL	BJKN-300-P
原料寬度	Unwind Width	620 mm (max)
原料直徑	Unwind Diameter	450 mm (max)
成品寬度	Rewind Width	50 ~ 300 mm
成品直徑	Rewind Diameter	700 mm (max)
紙管內徑	Core I.D.	Paper core 3", 5", 10"
機械速度	Machine Speed	10 ~ 200 m/min
電 壓	Power	220V / 380V / 440V, 3-PHASE, 50/60 HZ

由於本公司不斷的研究改進，本型號所示機械規格特性本公司有變更之權利，恕不另行通知。
All specifications, designs and characteristics shown on this catalogue are subject to change without prior notice.

machine

PRO DOING INDUSTRIAL CO. LTD.

No. 47, 22nd. Road, Taichung Industrial Park, Taichung City, Taiwan.

TEL: 886-4-2359-7712 FAX: 886-4-2359-7269

Email: prodoing@ms36.hinet.net http://www.prodoing.com

Quality Built,
High Performance,
Maximum Dependability....

切片機

CUTTING MACHINE WITH SERVO MOTOR

BJC-300-PS (representative)



27

SPECIFICATIONS 規格

型式	MODEL	BJC-300-P	BJC-300-PS
本機型另有切片機	Flexible Capacity	400, 500, 600 mm	400, 500, 600 mm
原料直徑	Unwind Diameter	600 mm (max)	700 mm (max)
原料內徑	Inside Dia. of Unwind	3", 5" or 10" paper core (optional)	3", 5" or 10" paper core (optional)
成品寬度	Cutting Width	50 ~ 300 mm (max)	50 ~ 300 mm (max)
成品長度	Cutting Length	400 mm (max)	400 mm (max)
機械速度	Machine Speed	0 ~ 250 m/min	0 ~ 400 m/min
電 壓	Power	220V / 380V / 440V, 3-PHASE, 50/60 HZ	

由於本公司不斷的研究改進，本型號所示機械規格特性本公司有變更之權利，恕不另行通知。
All specifications, designs and characteristics shown on this catalogue are subject to change without prior notice.

Pro Doing

PRO DOING INDUSTRIAL CO. LTD.

No. 47, 22nd. Road, Taichung Industrial Park, Taichung City, Taiwan.

TEL: 886-4-2359-7712 FAX: 886-4-2359-7269

Email: prodoing@ms36.hinet.net http://www.prodoing.com

複捲機

INSPECTION & REWINDER

BJRV-300 (representative)



SPECIFICATIONS 規格

型式	MODEL	BJRV-300P	BJRV-400P	BJRV-500P
原料寬度	Unwind Width	50 ~ 300 mm	50 ~ 400 mm	50 ~ 500 mm
原料直徑	Unwind Diameter	700 mm (max)	700 mm (max)	700 mm (max)
成品寬度	Rewind Width	300 mm	400 mm	500 mm
成品直徑	Rewind Diameter	700 mm (max)	700 mm (max)	700 mm (max)
紙管內徑	Core I.D.	Unwind 3", Rewind 3"	Unwind 3", Rewind 3"	Unwind 3", Rewind 3"
機械速度	Machine Speed	0 ~ 300 m/min	0 ~ 300 m/min	0 ~ 300 m/min
電 壓	Power	220V / 380V / 440V, 3-PHASE, 50/60 HZ		

由於本公司不斷的研究改進，本型號所示機械規格特性本公司有變更之權利，恕不另行通知。
All specifications, designs and characteristics shown on this catalogue are subject to change without prior notice.

Pro Doing

BAG MAKING MACHINERY
CONVERTING
EQUIPMENT FOR
FLEXIBLE MATERIALS

Quality Built,
High Performance,
Maximum Dependability....

Pro Doing



CONVERTING | EQUIPMENT FOR | FLEXIBLE MATERIALS

SHRINKABLE LABEL MAKING PROCESS

收縮標籤製造機

PRO DOING INDUSTRIAL CO. LTD.

No. 47, 22nd. Road, Taichung Industrial Park, Taichung City, Taiwan.

TEL: 886-4-2359-7712 FAX: 886-4-2359-7269

Email: prodoing@ms36.hinet.net <http://www.prodoing.com>

SPECIFICATIONS 規格		
MODEL	型號	BJK-300-P
Machine Speed	機械速度	10-200 mm/min
Unwind Width	原料寬度	620 mm (max)
Rewind Width	成品寬度	50-300 mm
Unwind Diameter	原料直徑	450 mm (max)
Rewind System	捲取方式	Paper core 3", 5", 10"
Rewind Roll Dia.	捲取直徑	700 mm (max)
Power Input	電 壓	220V. 2-phase. 50/60 HZ

SPECIFICATIONS 規格		
MODEL	型號	BJR-300-P
Unwind Width	原料寬度	50 - 300 mm
Unwind Diameter	原料直徑	600 mm (max)
Rewind Width	成品寬度	300 mm
Rewind Diameter	成品直徑	700 mm (max)
Rewind Core I.D.	紙管內徑	3", 5" Paper core
Machine Speed	機械速度	0-200 m/min
Power Input	電 壓	220V / 380V / 440 / 3-PHASE, 50/60 HZ

SPECIFICATIONS 規格		
MODEL	型號	BJC-300-PS
Flexible Capacity	本機型另有切片機	400, 500, 600 mm
Unwind Diameter	原料直徑	700 mm (max)
Rewind Length	成品長度	400 mm (max)
Rewind Width	成品寬度	50-300 mm (max)
Unwind Core I.D.	原料內徑	3", 5" or 10" paper core (optional)
Machine Speed	機械速度	0-400 pcs/min
Power Input	電壓	220V, 3-phase, 50/60 HZ

由於本公司不斷的研究改進，本型錄所示機械規格特性本公司有變更之權力，恕不另行通知。
All specifications, designs and characteristics shown on this catalogue are subject to change without prior notice.

Quality Built,
High Performance,
Maximum Dependability....

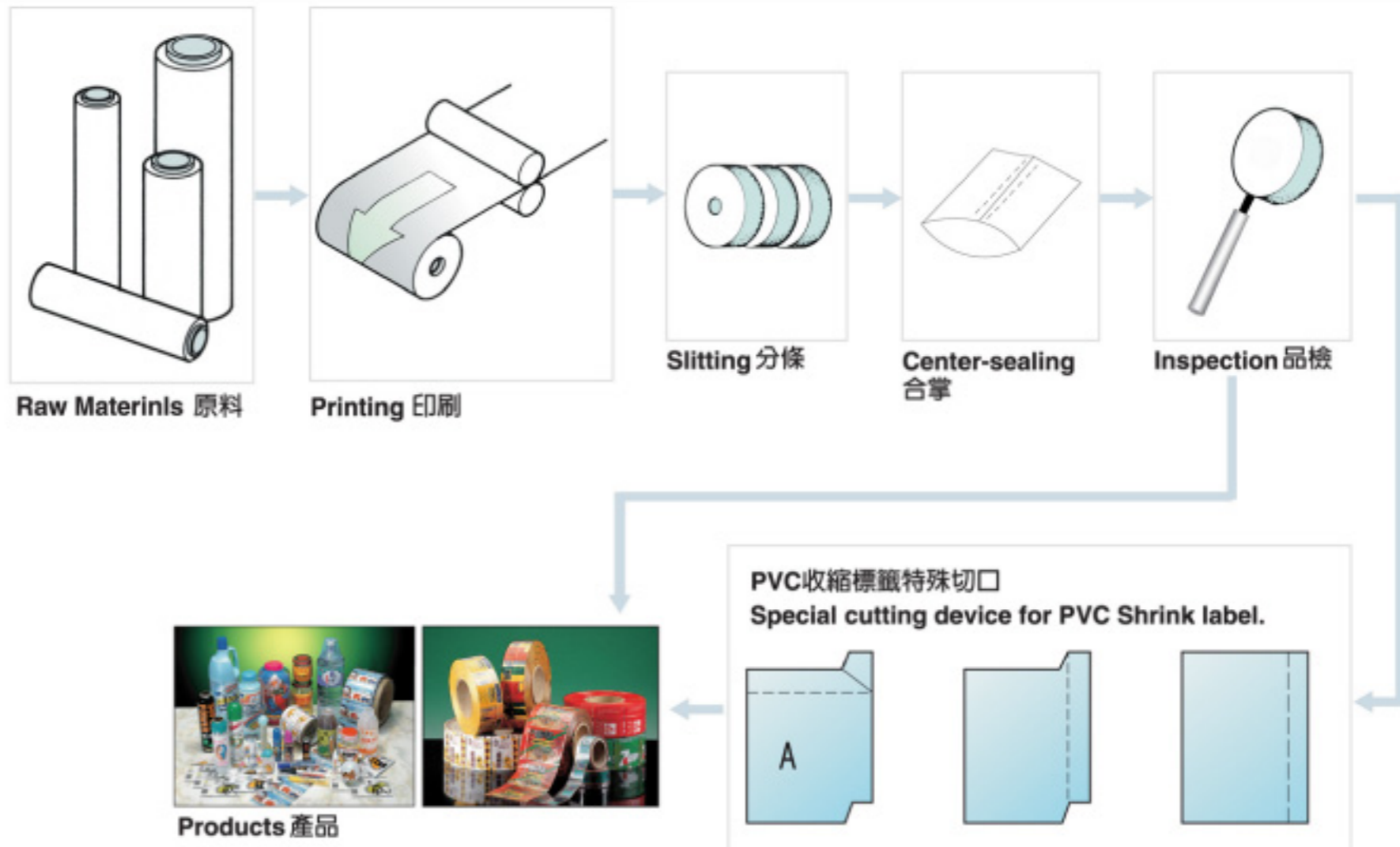

CENTER SEALING GLUING MACHINE 合掌機

傑出特性：

本機為生產不同材質之彩色收縮標籤而設計，操作簡便、保養容易、主動馬達採用DC無段變速，可依材質之不同，粘劑之流量及操作速度均可自由調整。

OUTSTANDING FEATURES:

This machine is designed and manufactured to be ideal for producing various materials of color shrink label. It is very easy to operate and maintain. The main drive on this machine employs a DC motor, offering variable speed adjustment to suit varying types of material, adhesive flow rate, and desired working speed.

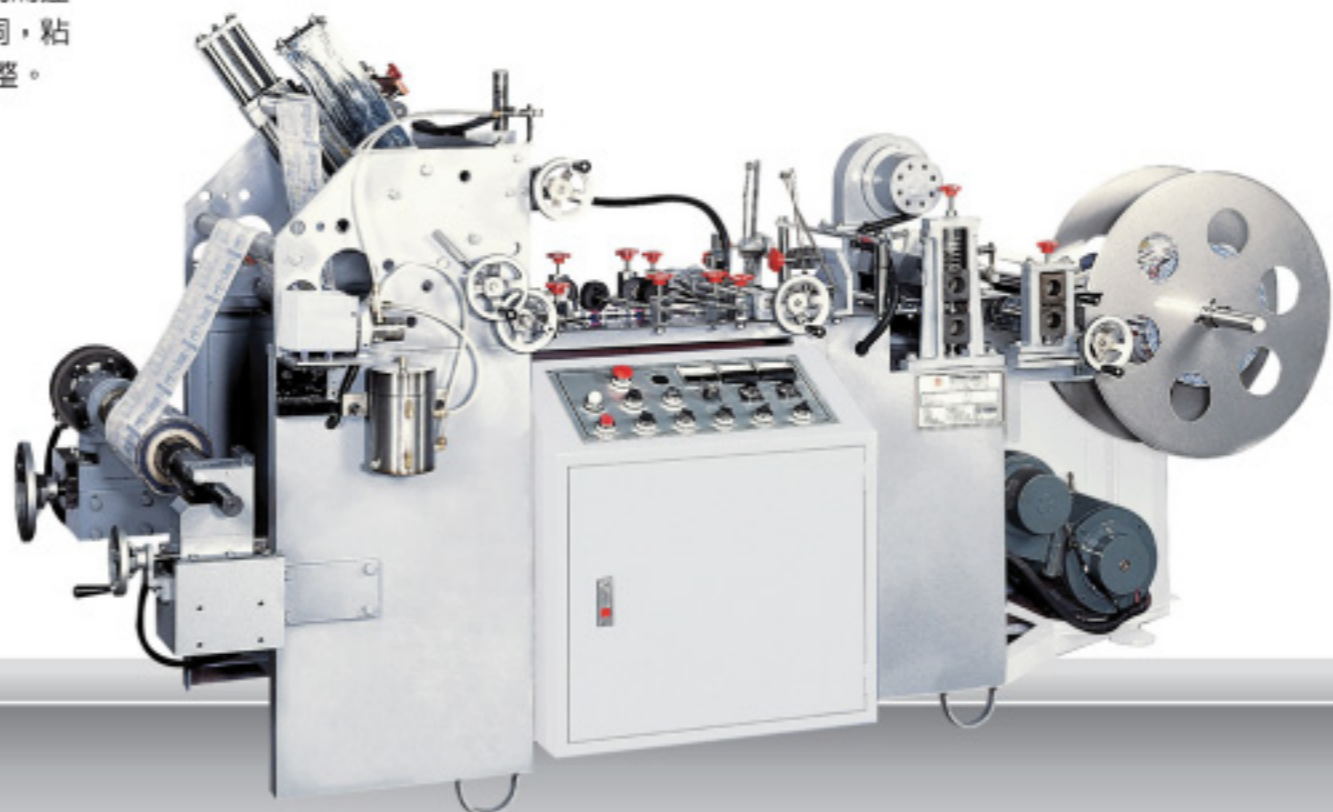

BJK series

PRO DOING INDUSTRIAL CO. LTD.

No. 47, 22nd. Road, Taichung Industrial Park, Taichung City, Taiwan.

TEL: 886-4-2359-7712 FAX: 886-4-2359-7269

Email: prodoing@ms36.hinet.net http://www.prodoing.com

RE-REELING & DOCTOR MACHINE 檢品複捲機

傑出特性：

本機精心設計，展現不凡的檢品及複捲性能。結構精良，操作容易。成品張力控制，採用磁粉式離合器，張力調整隨心所欲。原料座可針對各式不同特質做前後及左右調整。

OUTSTANDING FEATURES:

The Pro Doing BJR-1000 Inspection and Rewinder is quality engineered throughout to present an excellent inspection and rewinding performance. Quality construction ensures easy operation. Finished product tension control is adjusted with the magnetic powder-type clutch for adjusting as desired. Material stand may be crossly and longitudinally adjusted to meet the needs of various types of material.



BJR series

CUTTING MACHINE WITH SERVOMOTOR 切片機

傑出特性：

本機適用於PVC彩色收縮模標籤、紙及塑膠之切片作業。

OUTSTANDING FEATURES:

This machine is suited for PVC shrink film and various paper and plastic sheet cutting.



BJC series

PRO DOING INDUSTRIAL CO. LTD.

No. 47, 22nd. Road, Taichung Industrial Park, Taichung City, Taiwan.

TEL: 886-4-2359-7712 FAX: 886-4-2359-7269

Email: prodoing@ms36.hinet.net <http://www.prodoing.com>

Pro Doing

BAG MAKING MACHINERY
CONVERTING
EQUIPMENT FOR
FLEXIBLE MATERIALS

Quality Built,
High Performance,
Maximum Dependability....

Pro Doing



CONVERTING | EQUIPMENT FOR | FLEXIBLE MATERIALS

SHRINKABLE LABEL MAKING PROCESS (CE) 收縮標籤製造機 (CE)

PRO DOING INDUSTRIAL CO. LTD.

No. 47, 22nd. Road, Taichung Industrial Park, Taichung City, Taiwan.

TEL: 886-4-2359-7712 FAX: 886-4-2359-7269

Email: prodoing@ms36.hinet.net <http://www.prodoing.com>

SPECIFICATIONS 規格			
MODEL	型號	BJL-H1000-P	BJL-H1300-P
Unwind Width	原料寬度	300 - 1000 mm	300 - 1300 mm
Unwind Diameter	原料直徑	800 mm (max)	800 mm (max)
Product Width	成品寬度	50 - 1000 mm	50 - 1300 mm
Product Diameter	成品直徑	450 mm (max)	450 mm (max)
Rewind Core I.D.	紙管內徑	3"	3"
Machine Speed	機械速度	0 - 300 M/min	0 - 300 M/min
Power Input	電壓	220V / 380V / 440V, 3-phase, 50/60 HZ	220V / 380V / 440V, 3-phase, 50/60 HZ

SPECIFICATIONS 規格		
MODEL	型號	BJK-300-P
Unwind Width	原料寬度	620 mm (max)
Unwind Diameter	原料直徑	450 mm (max)
Rewind Width	成品寬度	50-300 mm
Rewind System	捲取方式	Paper core 3", 5", 10"
Rewind Roll Dia.	捲取直徑	700 mm (max)
Machine Speed	機械速度	10-200 mm/min
Power Input	電 壓	220V. 2-phase. 50/60 HZ

SPECIFICATIONS 規格		
MODEL	型號	BJR-300-P
Unwind Width	原料寬度	50 - 300 mm
Unwind Diameter	原料直徑	600 mm (max)
Rewind Width	成品寬度	300 mm
Rewind Diameter	成品直徑	700 mm (max)
Rewind Core I.D.	紙管內徑	3", 5" Paper core
Machine Speed	機械速度	0-200 m/min
Power Input	電 壓	220V / 380V / 440 / 3-PHASE, 50/60 HZ

SPECIFICATIONS 規格		
MODEL	型號	BJC-300-PS
Flexible Capacity	本機型另有切片機	400, 500, 600 mm
Unwind Diameter	原料直徑	700 mm (max)
Rewind Length	成品長度	400 mm (max)
Rewind Width	成品寬度	50-300 mm (max)
Unwind Core I.D.	原料內徑	3", 5" or 10" paper core (optional)
Machine Speed	機械速度	0-400 pcs/min
Power Input	電壓	220V, 3-phase, 50/60 HZ

由於本公司不斷的研究改進，本型錄所示機械規格特性本公司有變更之權力，恕不另行通知。
All specifications, designs and characteristics shown on this catalogue are subject to change without prior notice.

Quality Built,
High Performance,
Maximum Dependability....



Raw Materials 原料

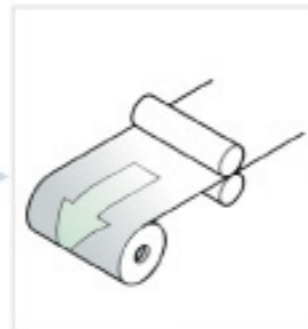

Printing 印刷

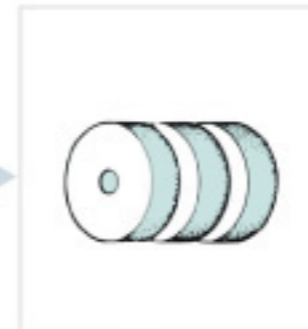

Slitting 分條

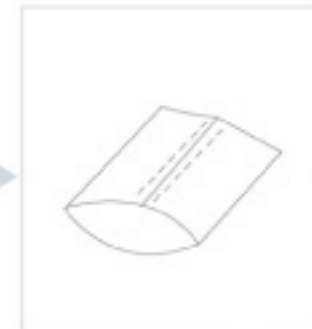

Center-sealing 合掌



Inspection 品檢

H TYPE SLITTING MACHINE H 型分條機

CE

傑出特性：

BJL-H系列分條機，展現優異的分條性能風範。此系列機種特別針對複合薄膜，及其他薄膜之分條機作業而設計。所效率及性能可靠度為設計製造之依循重點。簡易的操控特性，更可加裝系列特別配備如線及邊緣追蹤器(LPC)，原料張力全自動控制器...等，將分條運作特性提升至嶄新境界。

OUTSTANDING FEATURES:

The BJL-H series of Slitting Machines create superior slitting performance. Their design and engineering make them especially excellent for slitting composite films and various other materials. The entire machine is quality constructed to achieve high levels of performance and reliability and offers ease of operation. With a wide variety of optional equipment available such as Line & Edge Position Controllers (LPC), Automatic Tension Controllers...etc., this series of slitting machines provides maximum flexibility for slitting operations.



BJL-H series

CENTER SEALING GLUING MACHINE 合掌機

傑出特性：

本機為生產不同材質之彩色收縮標籤而設計，操作簡便、保養容易、主動馬達採用DC無段變速，可依材質之不同，粘劑之流量及操作速度均可自由調整。

OUTSTANDING FEATURES:

This machine is designed and manufactured to be ideal for producing various materials of color shrink label. It is very easy to operate and maintain. The main drive on this machine employs a DC motor, offering variable speed adjustment to suit varying types of material, adhesive flow rate, and desired working speed.



CE

BJK series

PRO DOING INDUSTRIAL CO. LTD.

No. 47, 22nd. Road, Taichung Industrial Park, Taichung City, Taiwan.

TEL: 886-4-2359-7712 FAX: 886-4-2359-7269

Email: prodoing@ms36.hinet.net http://www.prodoing.com

Pro Doing

PVC收縮標籤特殊切口
Special cutting device for PVC Shrink label.



Products 產品



RE-REELING & DOCTOR MACHINE 檢品複捲機

傑出特性：

本機精心設計，展現不凡的檢品及複捲性能。結構精良，操作容易。成品張力控制，採用磁粉式離合器，張力調整隨心所欲。原料座可針對各式不同特質做前後及左右調整。

OUTSTANDING FEATURES:

The Pro Doing BJR-1000 Inspection and Rewinder is quality engineered throughout to present an excellent inspection and rewinding performance. Quality construction ensures easy operation. Finished product tension control is adjusted with the magnetic powder-type clutch for adjusting as desired. Material stand may be crossly and longitudinally adjusted to meet the needs of various types of material.



CE

BJR series

CUTTING MACHINE WITH SERVOMOTOR 切片機

傑出特性：

本機適用於PVC彩色收縮模標籤、紙及塑膠之切片作業。

OUTSTANDING FEATURES:

This machine is suited for PVC shrink film and various paper and plastic sheet cutting.



CE

BJC series

PRO DOING INDUSTRIAL CO. LTD.

No. 47, 22nd. Road, Taichung Industrial Park, Taichung City, Taiwan.

TEL: 886-4-2359-7712 FAX: 886-4-2359-7269

Email: prodoing@ms36.hinet.net http://www.prodoing.com

Pro Doing

Pro Doing

BAG MAKING MACHINERY
CONVERTING
EQUIPMENT FOR
FLEXIBLE MATERIALS

Quality Built,
High Performance,
Maximum Dependability....



CONVERTING EQUIPMENT FOR FLEXIBLE MATERIALS

SLITTING MACHINE

分條機



PRO DOING INDUSTRIAL CO. LTD.

No. 47, 22nd. Road, Taichung Industrial Park, Taichung City, Taiwan.

TEL: 886-4-2359-7712 FAX: 886-4-2359-7269

Email: prodoing@ms36.hinet.net <http://www.prodoing.com>

SPECIFICATIONS		規格	
MODEL	型號	BJL-H1000	BJL-H1300
Unwind Width	原料寬度	300 - 1000 mm	300 - 1300 mm
Unwind Diameter	原料直徑	800 mm (max)	800 mm (max)
Product Width	成品寬度	50 - 1000 mm	50 - 1300 mm
Product Diameter	成品直徑	450 mm (max)	450 mm (max)
Rewind Core I.D.	紙管內徑	3"	3"
Machine Speed	機械速度	0 - 300 M/min	0 - 300 M/min
Power Input	電壓	220V / 380V / 440V, 3-phase, 50/60 HZ	220V / 380V / 440V, 3-phase, 50/60 HZ

SPECIFICATIONS		規格
MODEL	型號	BJL-A Type
Unwind Width	原料寬度	200 - 1000 mm
Unwind Diameter	原料直徑	600 mm (max)
Product Width	成品寬度	50 - 1000 mm
Product Diameter	成品直徑	420 mm (max)
Rewind Core I.D.	紙管內徑	3"
Machine Speed	機械速度	0 - 200 M/min
Power Input	電壓	220V / 380V / 440V, 3-phase, 50/60 HZ

SPECIFICATIONS		規格		
MODEL	型號	BJL-K1000	BJL-K1300	BJL-K1600
Unwind Width	原料寬度	300 - 1000 mm	400 - 1300 mm	600 - 1600 mm
Unwind Diameter	原料直徑	700 mm	700 mm	700 mm
Product Width	成品寬度	50-1000 mm	50-1300 mm	50-1600 mm
Product Diameter	成品直徑	450 mm	450 mm	450 mm
Rewind Core I.D.	紙管內徑	3"	3"	3"
Machine Speed	機械速度	0-250 m/min	0-250 m/min	0-250 m/min
Power Input	電 壓	220V / 380V / 440V, 3-phase, 50/60 HZ		

SPECIFICATIONS		規格
MODEL	型號	BJL-BK 1300
Unwind Width	原料寬度	300 - 1300 mm
Unwind Diameter	原料直徑	1000 mm
Product Width	成品寬度	50-1300 mm
Product Diameter	成品直徑	800 mm
Rewind Core I.D.	紙管內徑	3"
Machine Speed	機械速度	0-150 m/min
Power Input	電 壓	220V / 380V / 440V, 3-phase, 50/60 HZ

由於本公司不斷的研究改進，本型錄所示機械規格特性本公司有變更之權力，恕不另行通知。
 All specifications, designs and characteristics shown on this catalogue are subject to change without prior notice.

Quality Built,
High Performance,
Maximum Dependability....

H TYPE SLITTING MACHINE

H 型分條機

傑出特性：

BJL-H系列分條機，展現優異的分條性能風範。此系列機種特別針對複合薄膜，及其他薄膜之分條機作業而設計。所效率及性能可靠度為設計製造之依循重點。簡易的操控特性，更可加裝系列特別配備如線及邊緣追蹤器(LPC)，原料張力全自動控制器...等，將分條運作特性提升至嶄新境界。

OUTSTANDING FEATURES:

The BJL-H series of Slitting Machines create superior slitting performance. Their design and engineering make them especially excellent for slitting composite films and various other materials. The entire machine is quality constructed to achieve high levels of performance and reliability and offers ease of operation. With a wide variety of optional equipment available such as Line & Edge Position Controllers (LPC), Automatic Tension Controllers...etc., this series of slitting machines provides maximum flexibility for slitting operations.



BJL-H series

A TYPE SLITTING MACHINE

A 型分條機

傑出特性：

此系列分條機專用於玻璃紙，PET, OPP, PE, PVC等膠卷紙捲或積層材料之快速分條作業。本機放料軸採用水平迴旋式設計，提供方便，快速之置料即出料，只需單人即可輕鬆作業。原料軸可前後，左右調整。配備高性能控制器，操控簡易。作業速度快，產能高。並有廣泛系列之選購配備，使本機操作更方便即多功能性。

OUTSTANDING FEATURES:

Designed for high speed slitting of various film rolls and paper rolls, such as cellophane, PET, OPP, PE, PVC etc.. The unwinding and rewinding shafts feature horizontal swivelling for convenient, fast material loading and unloading, which require only a single operator to accomplish. The unwinding shaft can be adjusted forwards/backwards and right/left. The machine is equipped with a high performance controller for easy operation control. High speed slitting performance creates high productivity. When requested, a wide range of optional accessories are available for more convenient and versatile operations.

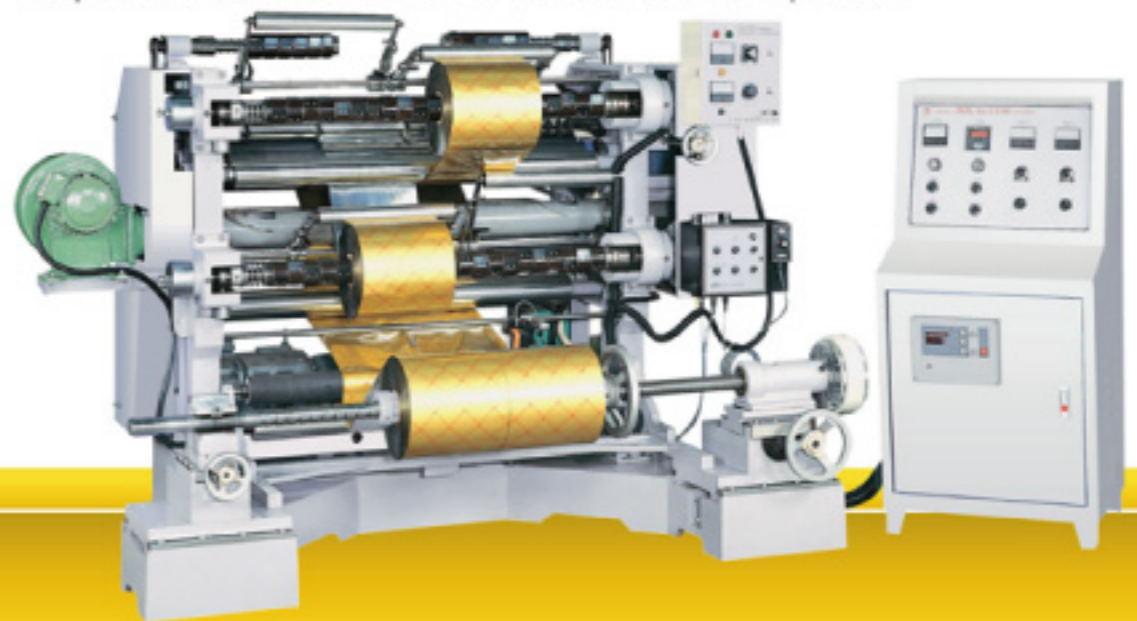

BJL-A series

PRO DOING INDUSTRIAL CO. LTD.

No. 47, 22nd. Road, Taichung Industrial Park, Taichung City, Taiwan.

TEL: 886-4-2359-7712 FAX: 886-4-2359-7269

Email: prodoing@ms36.hinet.net http://www.prodoing.com

K TYPE SLITTING MACHINE K 型分條機

傑出特性：

BJL-K系列分條機，展現優異的分條性能風範。此系列機種特別針對複合薄膜，及其他薄膜之分條機作業而設計。所效率及性能可靠度為設計製造之依循重點。簡易的操控特性，更可加裝系列特別配備如線及邊緣追蹤器(LPC)，原料張力全自動控制器...等，將分條運作特性提升至嶄新境界。

OUTSTANDING FEATURES:

The BJL-K series of Slitting Machines create superior slitting performance. Their design and engineering make them especially excellent for slitting composite films and various other materials. The entire machine is quality constructed to achieve high levels of performance and reliability and offers ease of operation. With a wide variety of optional equipment available such as Line & Edge Position Controllers (LPC), Automatic Tension Controllers...etc., this series of slitting machines provides maximum flexibility for slitting operations.

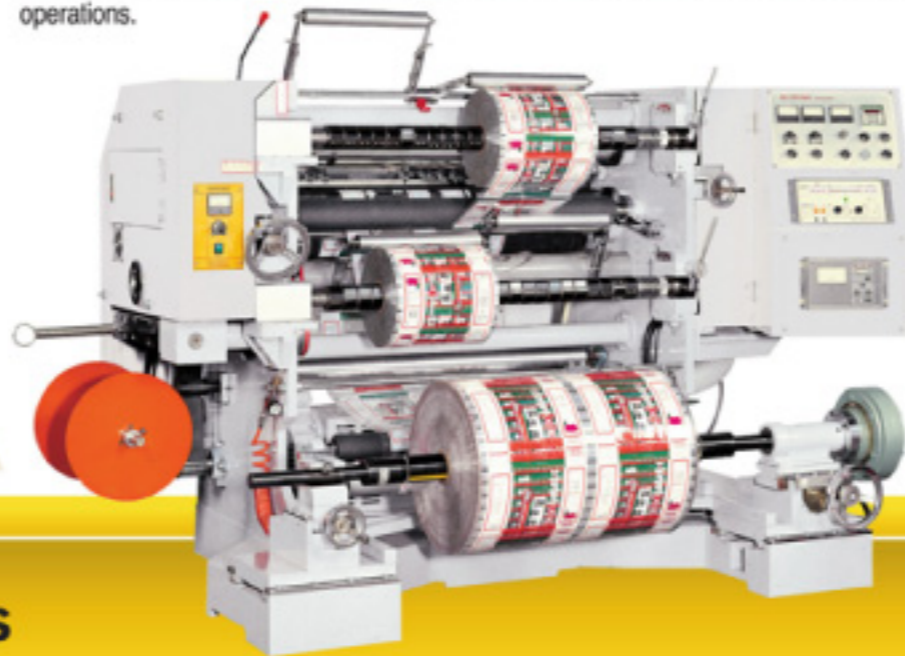

BJL-K series

BK TYPE SLITTING MACHINE BK 型分條機

傑出特性：

此系列分條機適合紙，貼紙，離型紙及OPP、PET膠膜等之快速分條作業。本機配備有兩組捲取軸，為表面中心捲取方式，可提升產品邊緣之整齊性。成品張力可依不同原料無段調整。機械結構剛強，高速作業穩定性高。放料軸配備可前後，左右調整。附有記米器，方便長度之設定。並有廣泛系列之選購配備，使本機操作更方便及多功能性。

OUTSTANDING FEATURES:

This series of slitting machine is suitable for high speed slitting of labels and isolated papers, etc.. The machine is equipped with two sets of rewinding shafts with surface center rewinding to upgrade product smoothness. Product tension can be variably adjusted to suit various materials. The machine is ruggedly constructed for maximum stability while in high speed operations. The unwinding shaft can be adjusted forward/backward and right/left. A length counter provides convenient length setting. When requested, a wide range of optional accessories are available for more convenient and versatile operation.



BJL-BK series

PRO DOING INDUSTRIAL CO. LTD.

No. 47, 22nd. Road, Taichung Industrial Park, Taichung City, Taiwan.

TEL: 886-4-2359-7712 FAX: 886-4-2359-7269

Email: prodoing@ms36.hinet.net http://www.prodoing.com



Pro Doing

PRO DOING INDUSTRIAL CO. LTD.
葆俊企業股份有限公司

台中市南屯區工業區22路47號1樓
No. 47, 22nd. Road, Taichung Industrial Park, Taichung City, Taiwan.
TEL: 886-4-2359-7712 FAX: 886-4-2359-7269
Email: prodoing@ms36.hinet.net <http://www.prodoing.com>

由於本公司不斷的研究改進，本型錄所示機械規格特性本公司有變更之權力，恕不另行通知。
All specifications, designs and characteristics shown on this catalogue are subject to change without prior notice.